

**RESPONSE™**  
DAYLIGHT   
Integrated Controls by Ledalite

# Design Guide



**LEDALITE**

---

Response® Daylight Design Guide © 2006 Ledalite Architectural Products. All rights reserved. L0266

# Introduction

---

Response Daylight offers a simple and affordable way to apply daylight controls to your lighting designs.

## Simple to specify

Specifying Response Daylight is as easy as specifying any 1cct fixture. The sensors are completely integrated in Ledalite luminaires with subtle aesthetics and simple circuitry so you don't have to specify standalone systems, low voltage wiring schemes or costly power packs. Just design the lighting as usual and indicate which fixtures require daylight controls.

## Virtually no commissioning

Late-night commissioning and third-party installers are a thing of the past. Response Daylight sensors are factory pre-calibrated for most typical lighting applications right out of the box – just plug in the fixture. If your space does require some fine-tuning in the field, Response Daylight sensors are easily adjusted onsite.



## About this Guide

This guide reviews the following topics:

- Understanding Control Zones
- Best Practices
- Suspended Applications
- Recessed Applications
- Planning and Specifying

## Additional Resources

The following resources are available for download from [www.ledalite.com/response](http://www.ledalite.com/response):

- Response Daylight Brochure
- Sensor Specifications
- Field Guide
- Response Daylight CAD Luminaire Library
- Response Daylight Product Selectors

# Understanding Control Zones

When daylight enters a space, there is an opportunity to save energy by using daylight sensors to reduce electric light output on a relative, compensating scale. But how should you apply controls to capitalize on this opportunity?

A good daylight controls design should leverage daylight contribution without disrupting occupants or sacrificing lighting quality. Here, it is important for designers to understand how daylight behaves in a space. Obviously daylight varies over seasons, throughout the day and even with passing weather. Daylight levels also gradually fall off as you move away from windows into the space. The amount of available daylight is further affected by the size and glazing of windows, room reflectances and desk and ceiling heights.

When designing with daylight controls, it's a good idea to create multiple control zones within the space to compensate for differences in available daylight and to satisfy light level requirements for different functional tasks. Each zone should be controlled by its own daylight sensor, optimally placed over a representative work area within that zone.

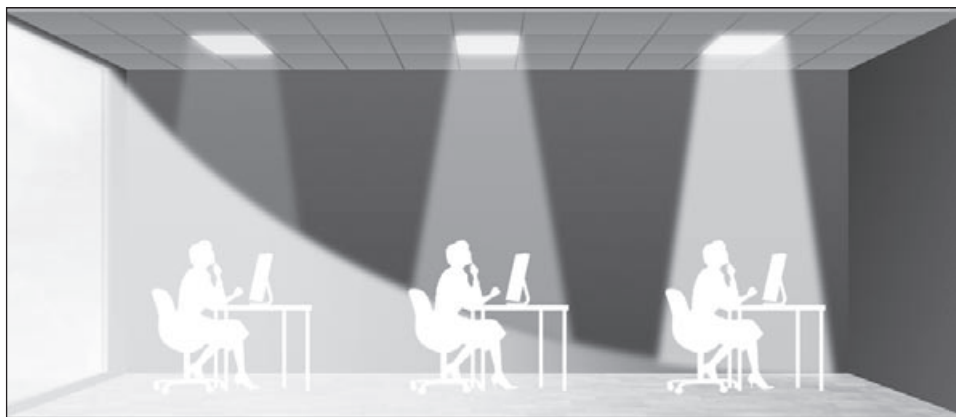

In this example, two control zones have been created within the area where there is adequate daylight contribution, and one non-controlled zone where daylight is negligible. As daylight contribution increases, sensors reduce electric light output on a relative, compensating scale.

## **Control zone 1**

Greatest amount of daylight contribution

## **Control zone 2**

Moderate amount of daylight contribution

## **Non-controlled**

Negligible amount of daylight contribution



# Best Practices

Every space is unique and, as such, every space will have different requirements for applying daylight controls. When designing with Response Daylight, Ledalite recommends running calculations on a project-specific basis. However there are some general guidelines you should follow to optimize sensor placement within any space.

## Optimal sensor placement

### Sensor should be located

- Between 6-10' from window
- Over representative work surfaces

### Sensor should not be located

- Outside the daylit zone\* (typically beyond 15' from window)
- Over very dark surfaces (e.g. dark carpet or furniture)
- Over highly reflective surfaces (e.g. polished floors or tables)

*\*NOTE: The size of the daylit zone is primarily a function of the size and exposure of windows. In a typical space, areas beyond 15' do not usually receive enough daylight contribution to warrant controls. Within the daylit zone, designers can create multiple control zones depending on the design of the space and the demands of functional tasks.*

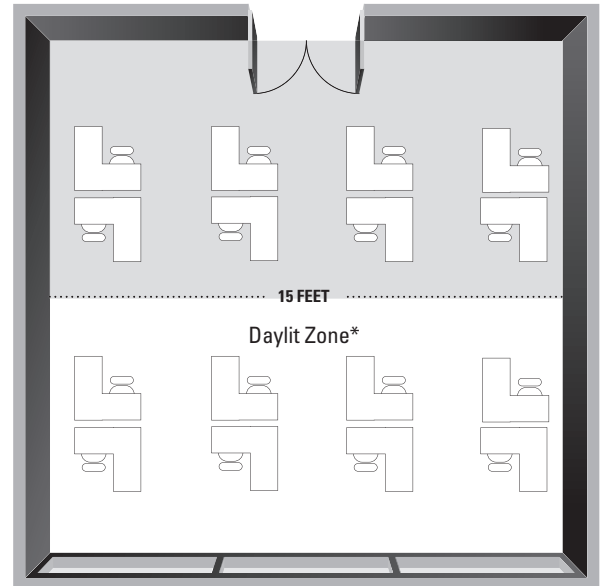

### Important

- Controlled fixtures must be placed so that there is at least five feet between sensors

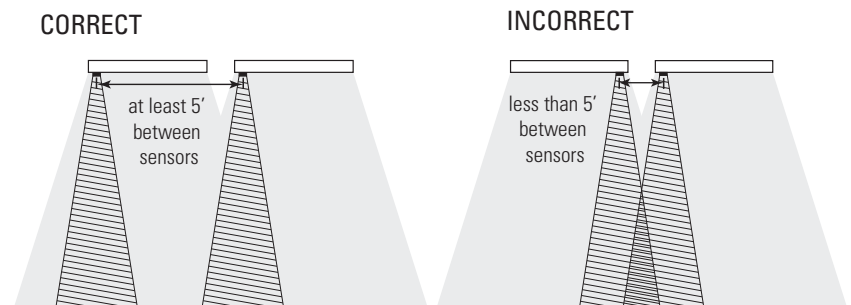

## Specific applications where Response Daylight is not recommended

- If a desired light level must be maintained with an accuracy greater than 10%, sensors with a higher performance should be used.
- If the building contains a wide variety of atypical rooms (e.g., in shape and decoration) with individual commissioning requirements, controls with optimized commissioning tools should be used.



# Suspended Applications

Ledalite's suspended products with Response Daylight offer architects and lighting designers critical flexibility and functionality for designing spaces with daylight control.

Ledalite suspended luminaires are themselves highly flexible, modular lighting systems designed for a wide range of applications and layouts. Most luminaires are available in 4ft, 8ft and 12ft modules with a range of lamping options (1 – 4 lamps depending on the product). Different modules can be joined together to form continuous runs of various lengths (see page 8 for details).

When integrated with Response Daylight sensors, Ledalite suspended lighting systems can be configured to accommodate almost any application. Response Daylight-controlled modules can be combined with non-controlled modules in a wide variety of configurations.

## Sensor placement and lamp control

Response Daylight sensors are integrated at different locations along a module to allow daylight dimming control over different sections of lamps and to enable optimal sensor placement over representative work areas.



### 4ft single-zone module (DS)

One photosensor controls all lamps in 4ft module.



### 8ft single-zone module (DS)

One photosensor controls all lamps in 8ft module.



### 12ft single-zone module (DS)

One photosensor controls all lamps in 12ft module.



### 12ft dual-zone module (DD)

Two photosensors in one 12ft module: one sensor controls all lamps in 4ft section, the other controls all lamps in 8ft section.

**Optimal sensor placement**

With Response Daylight, sensor placement is flexible and easily optimized for the space. Designers can combine different module lengths (4/8/12ft) and/or, rotate modules 180° to shift the sensor placement along a run (as shown left). This makes it easy for designers to optimize sensor placement over representative work areas.

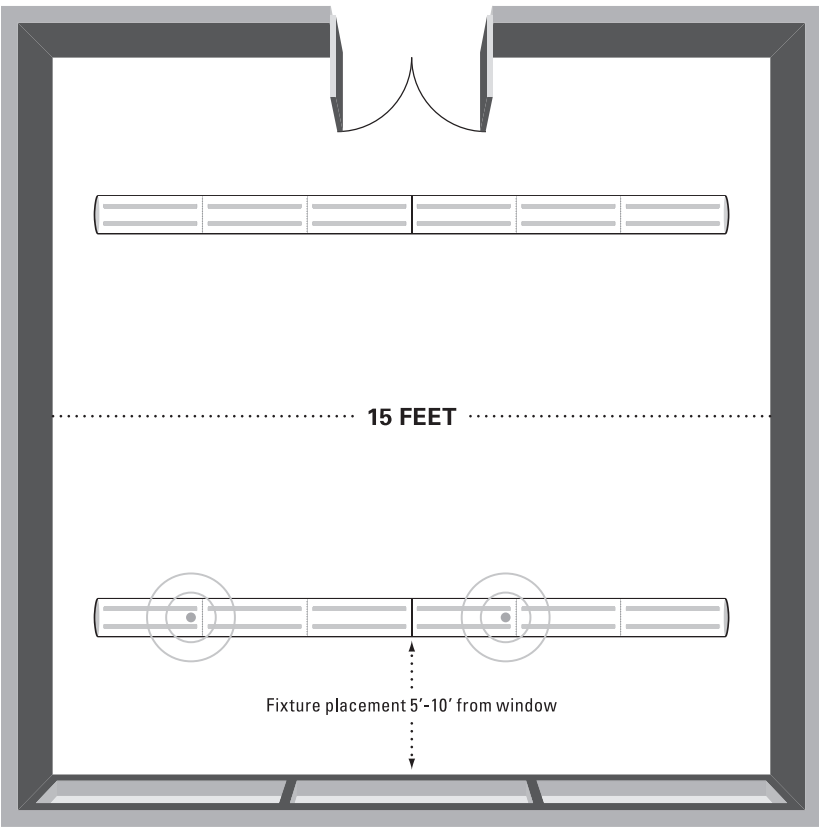

# Application 1

**12ft single-zone modules parallel to window.  
Typical classroom layout.**

Two 12ft single-zone modules are joined in a 24ft run that is suspended parallel to the window. In addition, two 12ft non-controlled modules are joined in a 24ft run that is suspended in the area outside the typical daylight zone (beyond 15' from window) where daylight contribution is negligible.

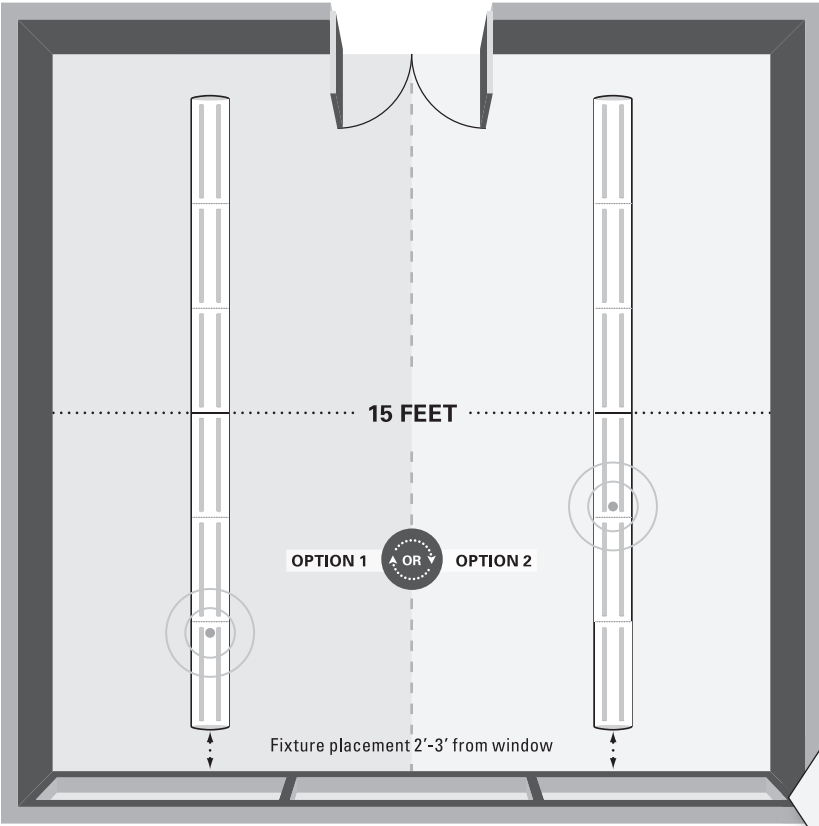

# Application 2

**12ft single-zone modules perpendicular to window.  
Typical open office layout.**

12ft single-zone modules are joined with 12ft non-controlled modules to create 24ft runs suspended perpendicular to the window.

The 12ft single-zone approach (with one sensor dimming all lamps equally in a 12ft module) is a simple way to save energy, but it does not compensate for daylight falloff as accurately as a dual-zone approach.

Controlled modules can be rotated 180° to optimize sensor placement over representative work areas.

## Application 3

**12ft dual-zone modules perpendicular to window. Typical open office layout.**

12ft dual-zone modules are joined with 12ft non-controlled modules to create 24ft runs suspended perpendicular to window.

The 12ft dual-zone approach (with two sensors measuring daylight and adjusting two separate sections of lamps accordingly) provides accurate compensation for daylight falloff throughout the space.

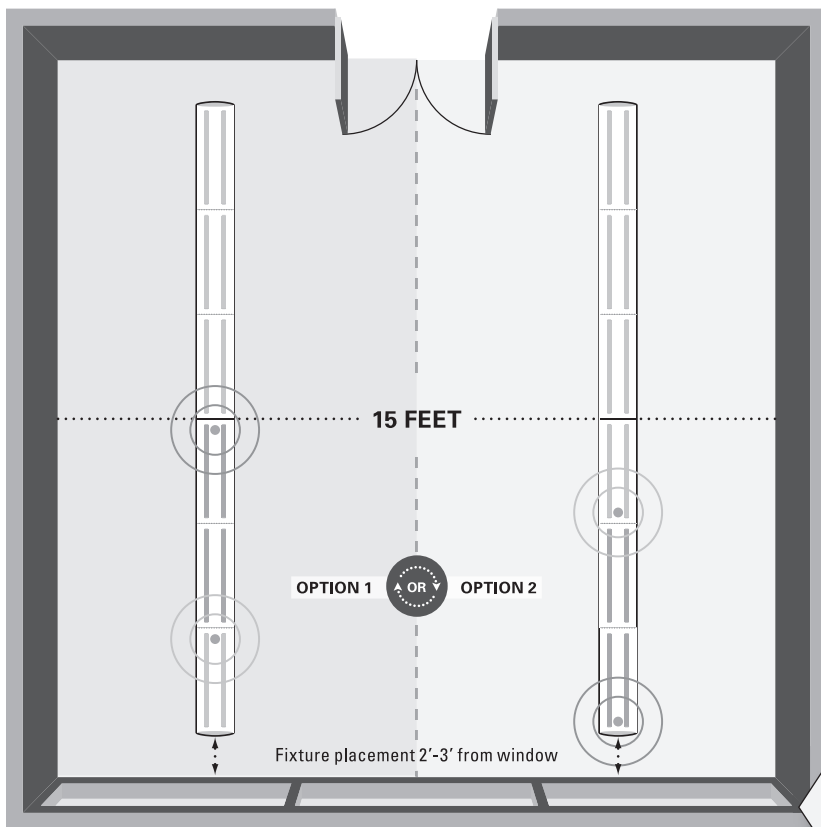

Controlled modules can be rotated 180° to optimize sensor placement over representative work areas.

## Application 4

**8ft single-zone modules (configured for dual-zone controls) perpendicular to window. Typical open office layout.**

24ft runs are created by joining two 8ft single-zone modules (each with one sensor that controls all lamps in the module) and one 8ft non-controlled module.

Combining two 8ft single-zone modules to create dual-zone controls provides accurate compensation for daylight falloff throughout the space. This application extends daylight dimming beyond the typical daylit zone (15' from window) which may be suitable for spaces with large windows, high ceilings and/or low furniture.

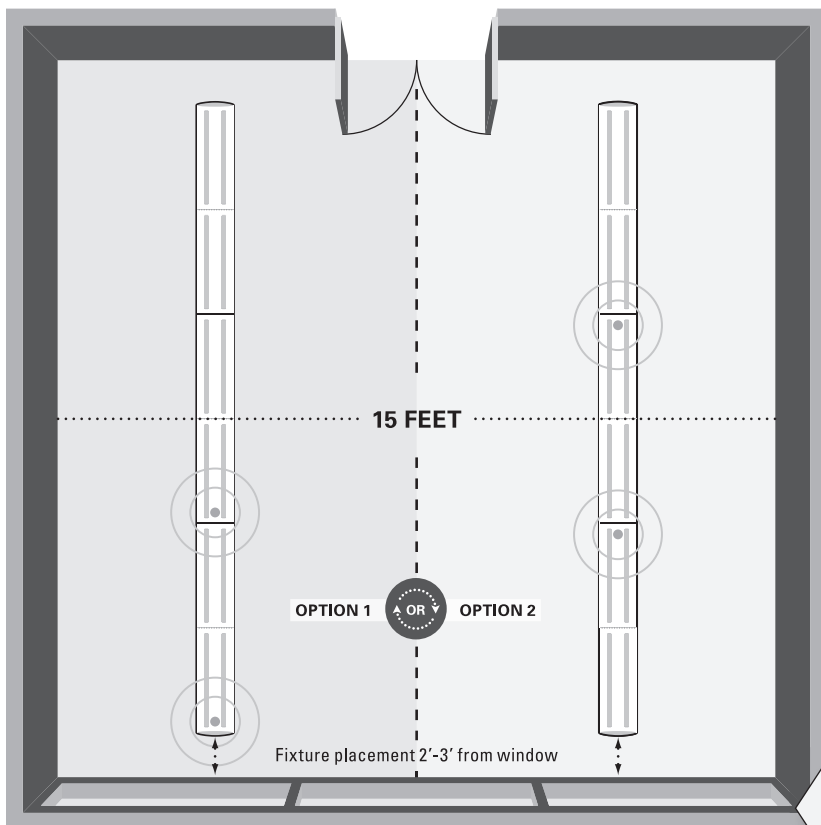

Controlled modules can be rotated 180° to optimize sensor placement over representative work areas.



# How to Make Runs

## Module lengths

Ledalite suspended products are available in 4/8/12ft modules. It's important to note that actual module lengths and mounting distances vary slightly depending on the product. Consult product spec sheets for details.

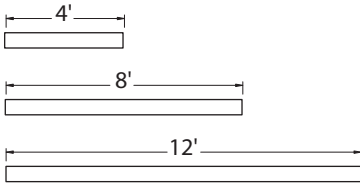

## Making runs

You can create continuous runs of various lengths by joining different modules together. The graphic (below) and the table (right) show some common run configurations using different modules. Remember to consult product spec sheets for exact module lengths and mounting distances.

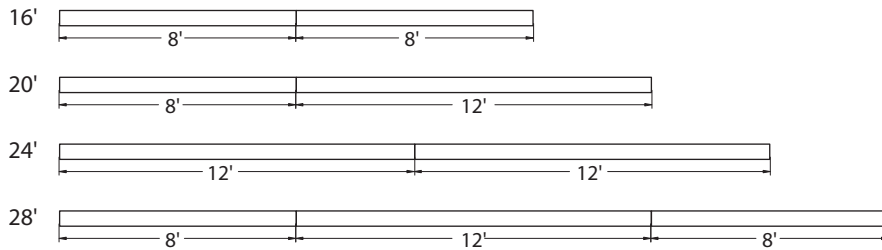

## Endcap Dimensions

Each run requires two endcaps, and each endcap adds to the length of a run. Consult product spec sheets for endcap dimensions.

**Run Configuration Table**

| Run Length* | 4' | 8' | 12' |
|-------------|----|----|-----|
| 16'         |    | 2  |     |
| 20'         |    | 1  | 1   |
| 24'         |    |    | 2   |
| 28'         |    | 2  | 1   |
| 32'         |    | 1  | 2   |
| 36'         |    |    | 3   |
| 40'         |    | 2  | 2   |
| 44'         |    | 1  | 3   |
| 48'         |    |    | 4   |
| 52'         |    | 2  | 3   |
| 56'         |    | 1  | 4   |
| 60'         |    |    | 5   |
| 64'         |    | 2  | 4   |
| 68'         |    | 1  | 5   |
| 72'         |    |    | 6   |
| 76'         |    | 2  | 5   |
| 80'         |    | 1  | 6   |
| 84'         |    |    | 7   |
| 88'         |    | 2  | 6   |
| 92'         |    | 1  | 7   |
| 96'         |    |    | 8   |
| 100'        |    | 2  | 7   |

*\*NOTE: Run lengths provided here are nominal. Actual module lengths vary by product and endcaps. Consult product spec sheets for exact dimensions.*

# Recessed Applications

Ledalite's recessed luminaires with MesoOptics® technology are a natural fit for architects and lighting designers who want to bring the best of nature's luminous aesthetics to indoor environments.

These innovative luminaires provide unique optical control capabilities, exceptional visual comfort and dramatic energy savings over conventional recessed systems. They are available in a range of sizes and lamping options and can be installed in continuous rows or as standalone units in a grid.

When integrated with Response Daylight, these luminaires provide even more energy efficiency while also offering design flexibility and simplicity for your daylighting designs.

Sensors can be integrated in standard 2x2 and 2x4 luminaires and configured to accommodate virtually any sensor placement and zoning requirements. A single recessed fixture with a Response Daylight sensor can control all lamps in up to nineteen additional standard dimming fixtures, minimizing controls costs and maximizing energy savings.

## Sensor placement and lamp control

One integrated photosensor controls all lamps in 2x2 or 2x4 fixture. Ledalite allows up to 19 regular dimming recessed fixtures to be connected to a single Response Daylight recessed fixture\*, so that all dim together in response to changing daylight levels. However, it may still be advisable to create multiple control zones, so that occupants receive the appropriate amount of light for their workspace.

*\*NOTE: The sensor can control up to 20 dimming ballasts, which, in most situations, enables one recessed fixture with integrated photosensor to control up to 19 additional standard dimming fixtures. Certain lamping configurations may support fewer fixtures.*

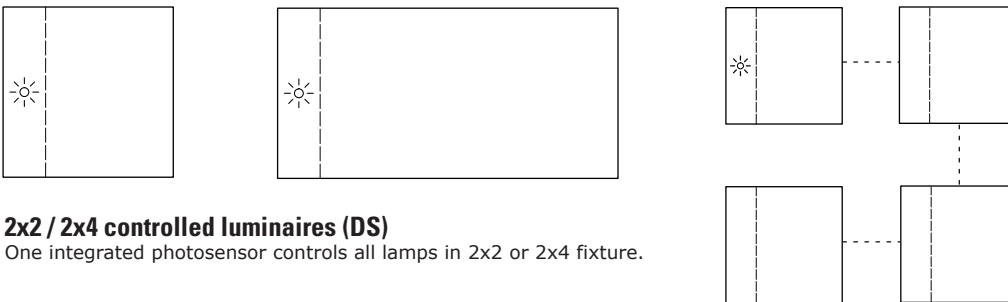

**2x2 / 2x4 controlled luminaires (DS)**  
One integrated photosensor controls all lamps in 2x2 or 2x4 fixture.

### Optimal sensor placement



Designers can rotate the fixture's orientation to optimize sensor placement over representative work areas.

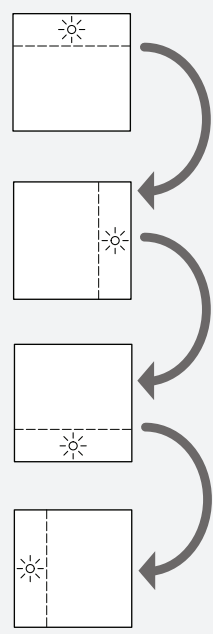

The diagram shows four 2x2 fixtures arranged vertically. Each fixture has a sun icon in a different position (top-left, top-right, bottom-left, bottom-right), and curved arrows indicate that the fixtures can be rotated to place the sensor in the optimal position for the work area below.

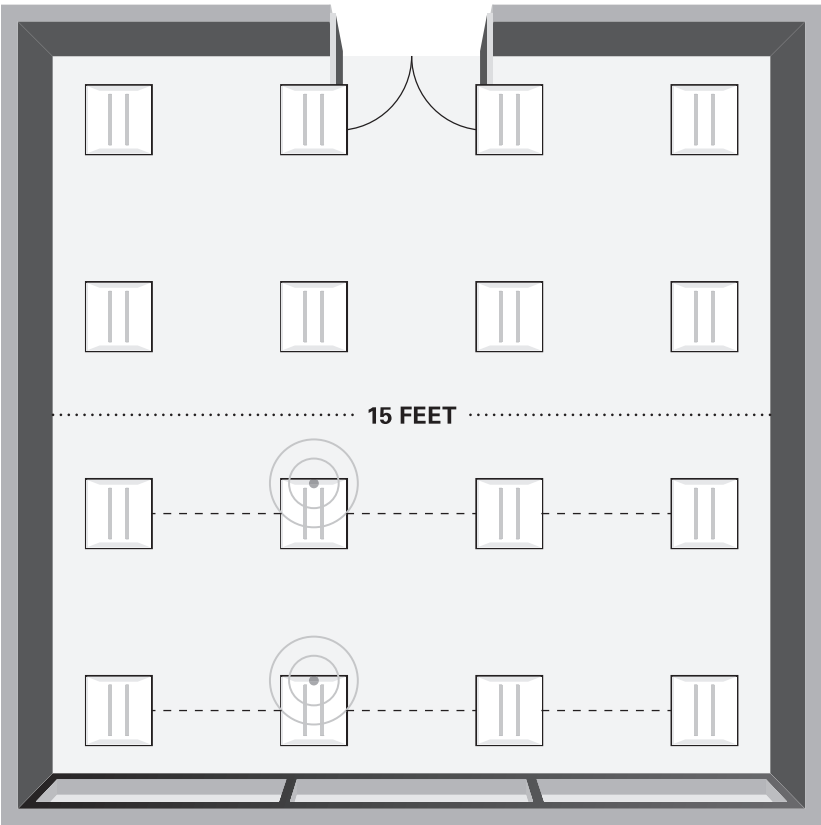

# Application 1

**Two 2x2 luminaires with integrated daylight sensors control two separate zones. Typical open office layout.**

2x2 luminaires are installed on 8x8 centers. Two separate control zones are created within the typical daylight zone (15' from window) by using two luminaires with integrated daylight sensors. Each sensor controls a total of four luminaires within its zone.

Non-controlled luminaires are used in the area outside the typical daylight zone where daylight contribution is negligible.

The use of a single sensor to control multiple luminaires within a zone maximizes savings on daylight sensors.

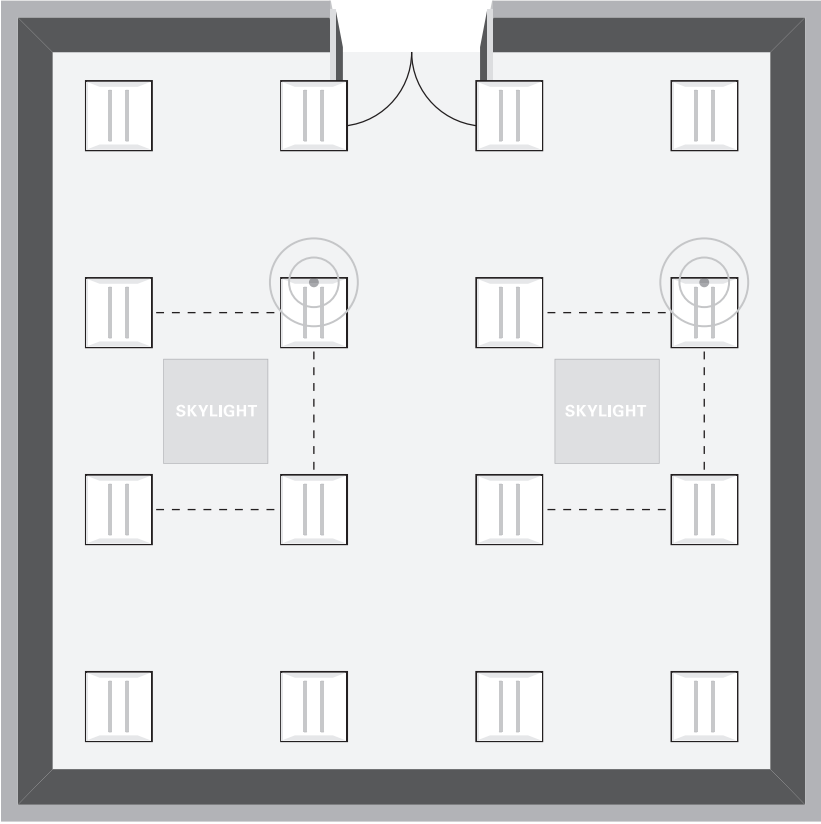

# Application 2

**Two 2x2 luminaires with integrated daylight sensors control two separate zones to compensate for skylight contribution. Typical open office layout with skylight.**

To accommodate daylight contribution from skylighting, two separate control zones are created by using two luminaires with integrated daylight sensors. Each sensor controls a total of four luminaires within its zone. Non-controlled luminaires are used in the areas where daylight contribution is negligible.

# Planning and Specifying

## Pick a product

Response Daylight is elegantly integrated in virtually every standard suspended and recessed Ledalite product, however, there are some exceptions. To verify which luminaires can be ordered with daylight sensors, look for the Response-Ready icon on specification sheets and product web pages. The website also maintains an up-to-date product selector detailing which suspended and recessed products are available with Response Daylight.



## Specify

Once you have selected a product, all you have to do is add two letters to the end of the fixture's catalog number on your specification documentation.

|               |  |
|---------------|--|
| <b>DS</b>     | Indicates Response Daylight in recessed 2x2/2x4 and suspended 4/8/12ft single-zone modules   |
| <b>DD</b>     | Indicates Response Daylight in suspended 12ft dual-zone modules  |
| <i>Sample</i> | <div style="border: 1px solid black; border-radius: 15px; padding: 10px; display: inline-block;"> <p>fixture catalog number ↘</p> <p><b>9506T02CN1272EW – DS</b></p> <p>2 letters to indicate Response Daylight ↗</p> </div> |

## Design

Designing spaces with Response Daylight isn't complicated, but you will achieve the best results if you do some planning upfront. Ledalite strongly recommends that specifiers provide fixture layout drawings in conjunction with furniture plans so you can ensure sensors are optimally placed over work surfaces. Providing this detail will greatly improve ordering, installation and the performance of the system.

This example uses the CAD luminaire library to indicate how two 32ft runs are configured in a space with two windows.

### Response Daylight CAD luminaire library

Ledalite has created a CAD luminaire library, compatible with all popular design programs, that can be placed on room layouts to indicate sensor placement. Simply download the library and drop the graphics into your drawings as required to indicate fixture and sensor placement.

Download from: [www.ledalite.com/response](http://www.ledalite.com/response)

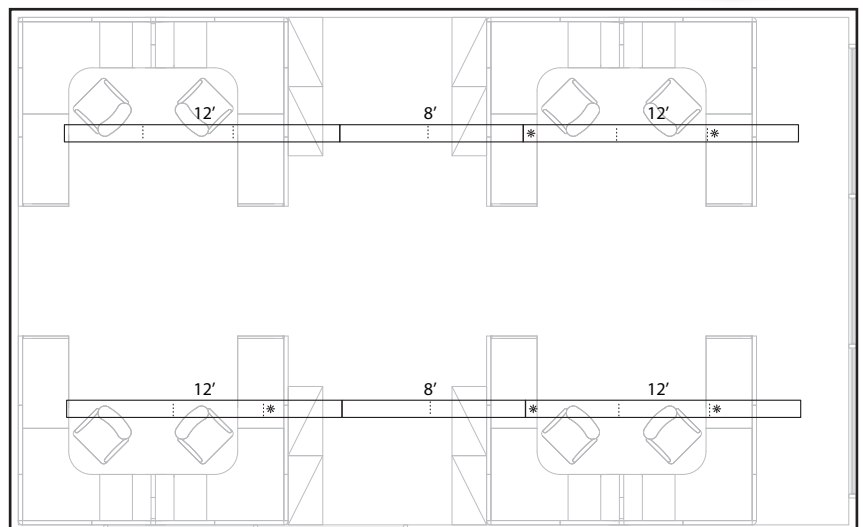



# **LEDALITE**

A Genlyte Company

Ledalite Architectural Products

19750 – 92A Avenue

Langley, B.C.

Canada, V1M 3B2

Tel: 604-888-6811

Toll free fax: 800-665-5332 (LEDA)

Email: [info@ledalite.com](mailto:info@ledalite.com)

[www.ledalite.com](http://www.ledalite.com)