

Recessed Shine (33), Pique (91), PureFX (94), Vectra (97) and Voice (98)

Continuous Row Installation Instructions

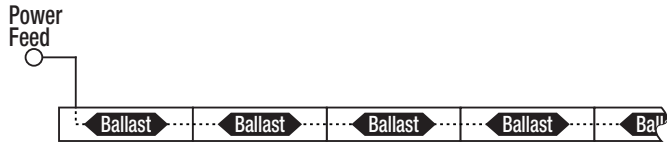

Fixtures are joined together in a continuous row and serviced by one power feed. Thru-wiring is provided, with quick-wire connectors and knock-outs at fixture ends. Every fixture contains its own ballast.

! DRYWALL

If installing in DRYWALL, some steps on this instruction sheet may not be applicable. Refer to separate drywall instruction sheet.

1 Bend mounting tab

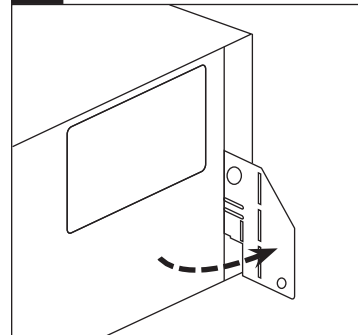

Bend out mounting tab 90 degrees on each corner.

2 Adjust height of tab

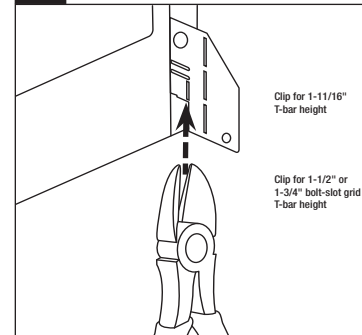

Use side cutters to adjust each tab to height of T-grid.

3 Lay fixture into T-grid

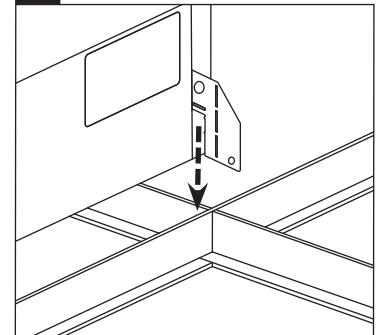

Lay fixture into T-grid.

4 Bend tabs flush

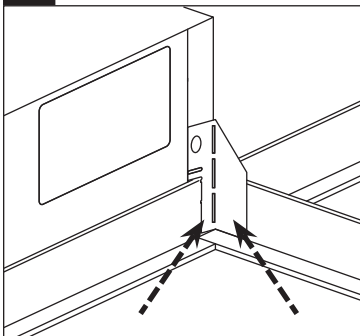

Bend tabs flush against T-grid in order to clear corner for ceiling tile.

5 Fasten fixture to T-grid

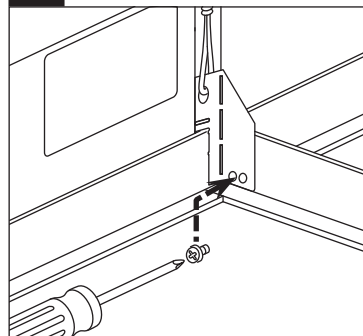

Use a #8x1/4" sheet metal screw to fasten fixture to T-grid and use a hanger wire to tie off appropriately in accordance with local building codes (screws and hanger wires supplied by others).

6 Attach adjacent fixtures

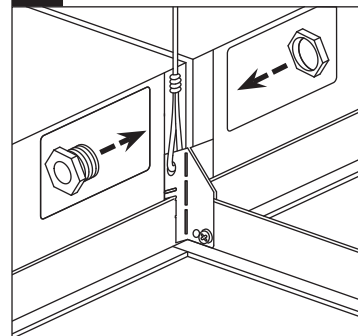

Remove connecting knock-outs and attach adjacent fixtures to the T-grid following steps 1-5. Place a 1/2" nipple through the knock-out hole between the fixtures. Fasten with a 1/2" NPT lock nut (nipple and lock nut supplied by others).

7 Electrical connections between fixtures

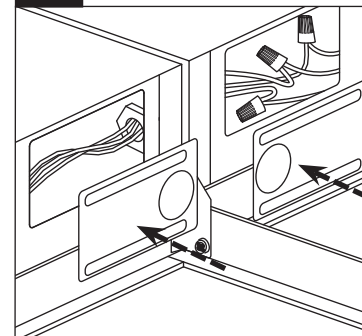

Feed the wires through the nipple and make all the electrical connections between the fixtures following the correct wiring color code. Attach the wiring access cover plates.

8 Electrical connection to the first fixture

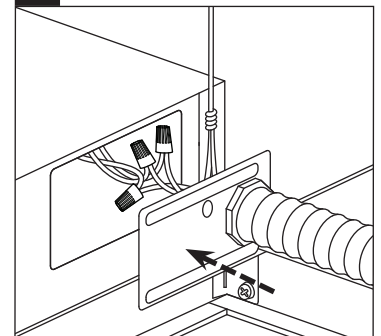

Ensure that the wiring of the last fixture in the row is properly terminated. Then make all electrical connections to the first fixture in the row. Attach the wiring access cover plate.

! ATTENTION: Install in accordance with national and local building and electrical codes.

ID-Recessed_CR.pdf

Page 1