

### Installation Instructions – Aircraft Cable Mount

- ① Read All Installation Instructions Before Installing Fixtures.
- ② Layout boxed fixtures on floor in desired mounting locations. Remove fixtures from boxes but keep the protective plastic on during installation.
- ③ General installation sequence:
  - (A) Install ceiling mounting kits (see below).
  - (B)&(C) Attach fixtures to mounting brackets at ends and joints (see below).

**ATTENTION**  
 INSTALL IN ACCORDANCE TO NATIONAL  
 AND LOCAL ELECTRICAL CODES AND  
 BUILDING CODES.

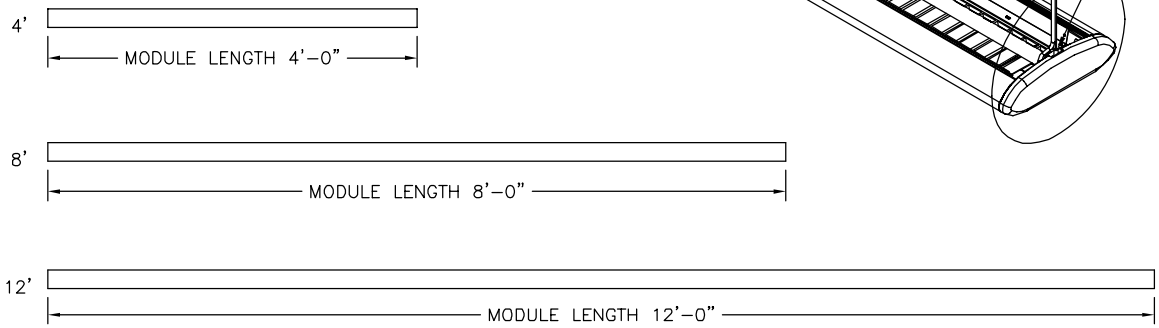
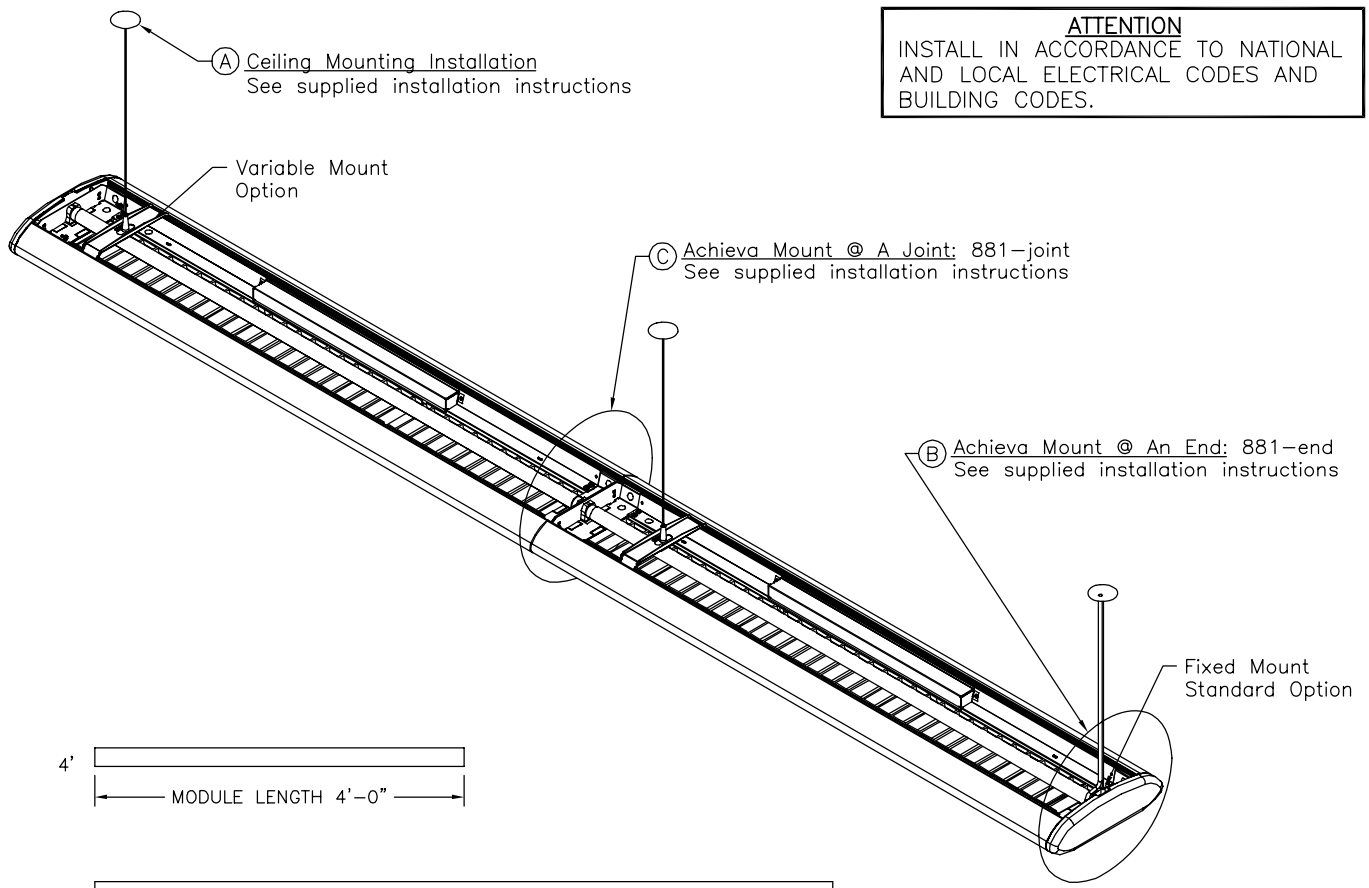

Overall Fixture Lengths

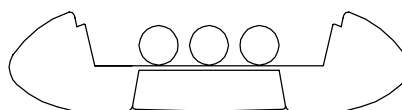

Cross Section

## Installation Instructions

- ① Install ceiling components.  
(See supplied "Mounting Installation" instructions.)
- ② Attach applicable mount bracket to fixture (fixed or variable). Fixed mounts use single screw, optional variable mounts slide into extrusion chase.
- ③ Insert aircraft cable through aircraft adjuster in mount bracket.
- ④ To ensure all mounting components have been installed correctly, temporarily apply a 25 lb. load to each mounting bracket location.
- ⑤ Hang other end of fixture using same procedure.
- ⑥ For a power feed location, break required 1/2 inch knock-out(s) in wire access cover and insert supplied bushing(s). In the case of a variable mount, feed power cord along reflector and through as shown. Use strain relief under wire access cover to secure cable. Remove installed quick-wire connectors at power feed location and complete electrical connections using wirenuts (supplied by others).
- ⑦ Confirm fixtures are level; if not, make fine adjustments as required using the release key. Cut aircraft cable to length. In the case of a variable mount, ensure the cable is at least flush with the bottom of the adjuster and there is no more than 2mm [.078 inches] of cable below the adjuster.
- ⑧ Attach endcaps with supplied hardware. If using optional variable bracket, secure mount bracket and aircraft adjuster in place with supplied hardware.

**ATTENTION**  
INSTALL IN ACCORDANCE TO NATIONAL AND LOCAL ELECTRICAL CODES AND BUILDING CODES.

**NOTE:**  
VARIABLE MOUNTING OPTION MUST BE ORDERED SEPARATELY

**NOTE:**  
NO VARIABLE MOUNTS ON 4' FIXTURES

Power Feed Connection

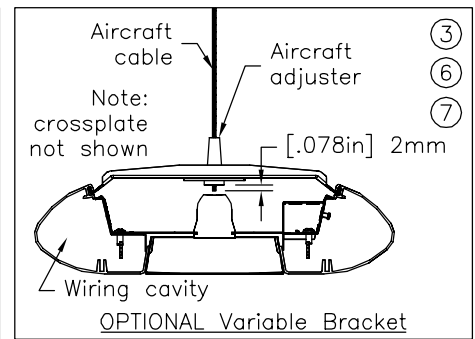
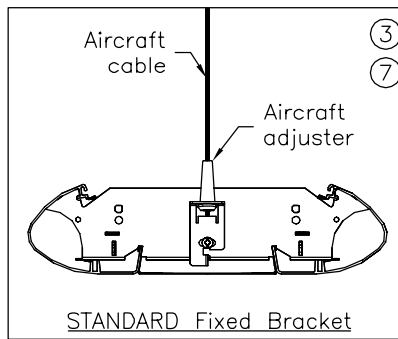
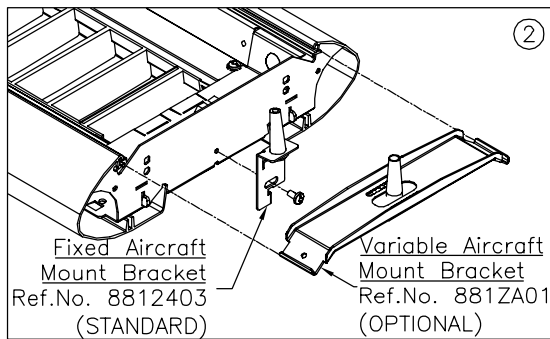

**ATTENTION: AIRCRAFT CABLE ADJUSTER**

To ensure quick and easy installation when using the aircraft adjusters follow these simple steps:

1. Be sure to cut cable ends cleanly prior to inserting into adjuster. Recommended cutters, H.K. Porter cable cutter cat. No. 0690TN or Klein all purpose shears cat. No. 1104.
2. Carefully insert cable straight into tapered end.
3. DO NOT FORCE CABLE INTO ADJUSTER. If cable does not insert easily or becomes jammed during insertion, use the release tool provided to remove cable, trim end again and repeat process. DO NOT ALLOW CABLE TO BEND BELOW BOTTOM OF ADJUSTER.
4. Once cable is inserted in position, apply a 25 lb. point load to each mount bracket to ensure all connections are secure.

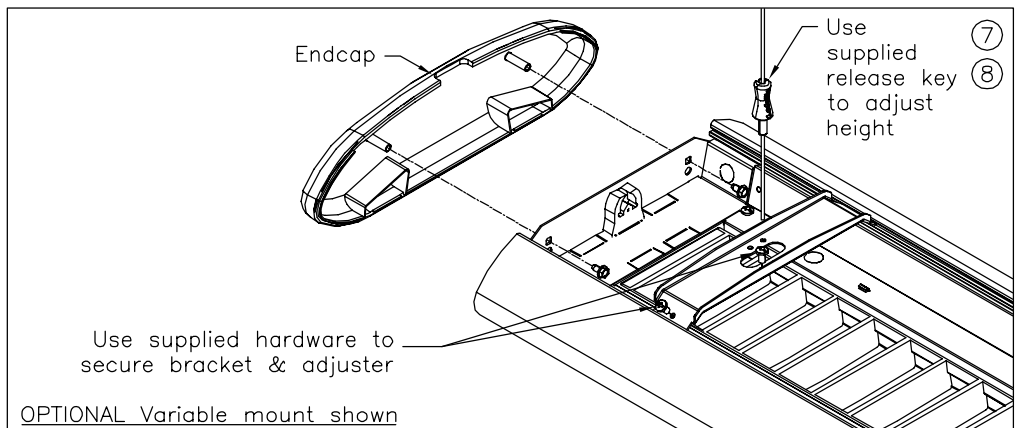
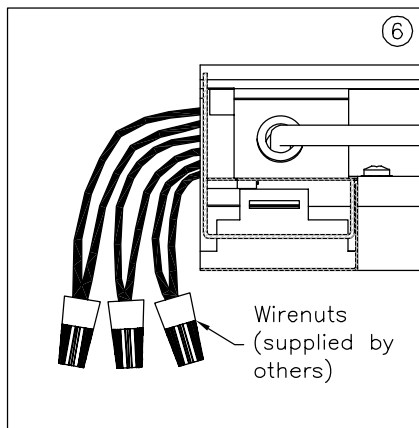
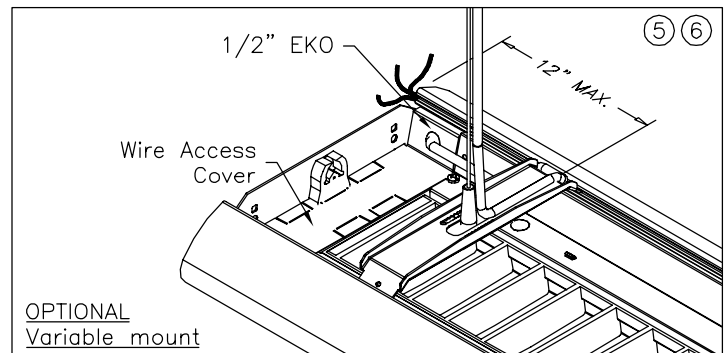

## Installation Instructions

**ATTENTION**  
 INSTALL IN ACCORDANCE TO NATIONAL  
 AND LOCAL ELECTRICAL CODES AND  
 BUILDING CODES.

Power Feed  
 Connection

- ① Install ceiling components.  
 (See supplied "Mounting Installation" instructions.)
- ② After installing first fixture, insert joiners into crossplates and lock in place. Set next fixture on joiners ensuring fixture is held by hooks of joiner ends.
- ③ Attach applicable mount (fixed or variable) in opposite end of fixture and insert aircraft cable into adjuster.
- ④ To ensure all mounting system components have been installed correctly, temporarily apply a 25 lb. point load to each mounting bracket location.
- ⑤ For a power feed location, break required 1/2 inch knock-out(s) in wire access cover. Insert supplied bushing(s) and feed power cord along reflector and through as shown. Use strain relief under wire access cover to secure cable. Remove installed quick-wire connectors at power feed location and complete electrical connections using wirenuts (supplied by others). Ensure that all connections are properly matched, capped, and tucked into fixture wiring cavity.
- ⑥ For a non power location, push wires into supplied quick-wire connectors. **DO NOT TWIST WIRES PRIOR TO CONNECTION. If power supply wires are on opposite sides of fixture, remove wire access cover (see 5). Bring power wires to one side and complete connections as shown (see 6).** Ensure that all wiring connections are properly matched, capped, and tucked into fixture wiring cavity. Replace wire access cover and associated screws if necessary.
- ⑦ Secure fixtures together using hardware supplied in joint kit. Ensure star washer faces the crossplate.
- ⑧ Confirm fixtures are level; if not, make fine adjustments as required using the release key. Cut aircraft cable ensuring it is at least flush with bottom of adjuster and there is no more than 2mm [.078 inches] below the adjuster (See supplied "Achieva Mount @ End" instructions for aircraft adjuster details).
- ⑨ Secure mount bracket & aircraft adjuster in place with supplied hardware.

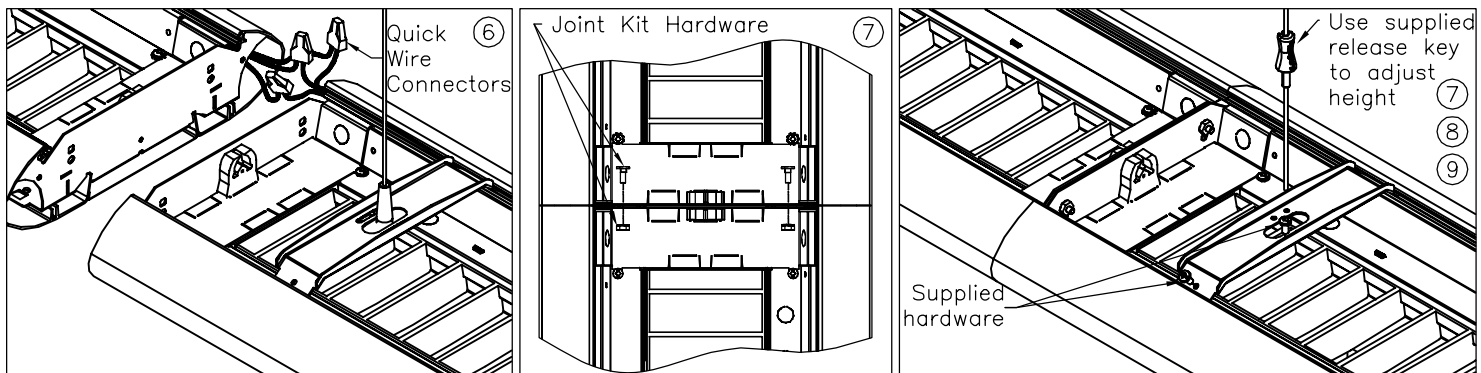
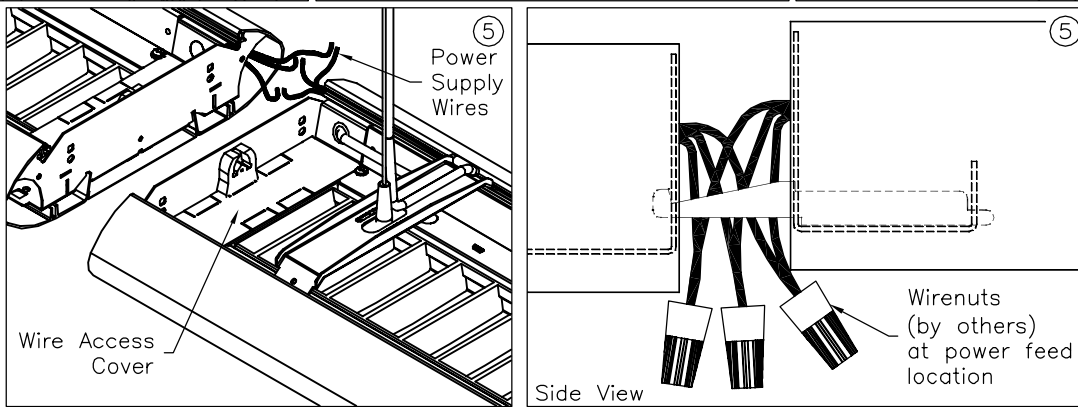
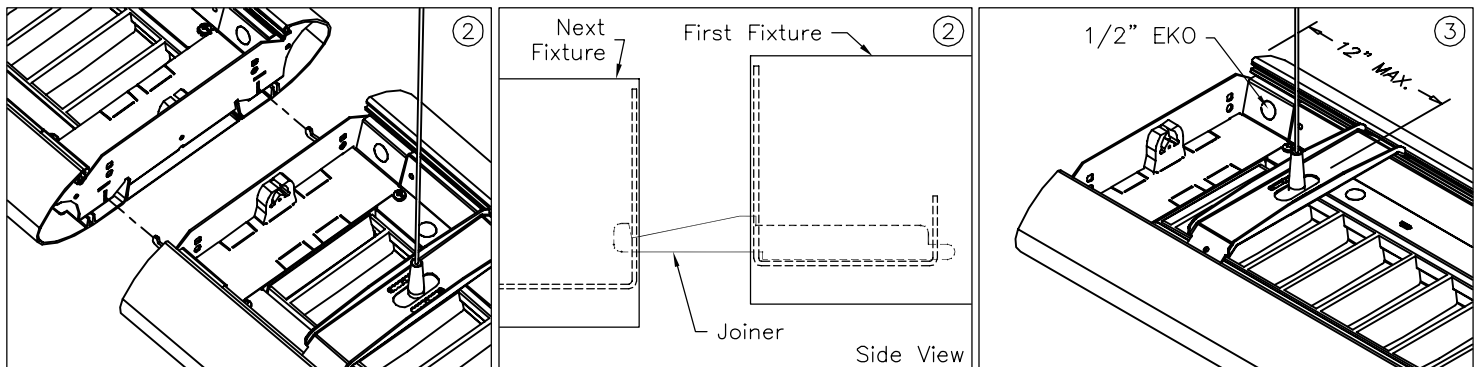

## Installation Instructions

**ATTENTION**  
 INSTALL IN ACCORDANCE TO NATIONAL  
 AND LOCAL ELECTRICAL CODES AND  
 BUILDING CODES.

- ① Install fixtures first.  
 (See supplied specific installation instructions that apply.)
  - ② Insert joiners into the installed fixtures cross plates.  
 Slide corner onto the joiners from one of the fixtures; bolt together the corner using provided hardware with the joint kit. Do the same sequence with the other side of the corner attaching it to the other fixture.
  - ③ Place corner cover on top of the corner and secure it with the supplied hardware.
- ①,② Shows corner assembling with fixed mounts.  
 ③,④ Shows corner assembling with variable mounts. Do not exceed 12" from end of fixture to mount.  
 ⑤ Shows typical mount locations relative to corner's dimensions.

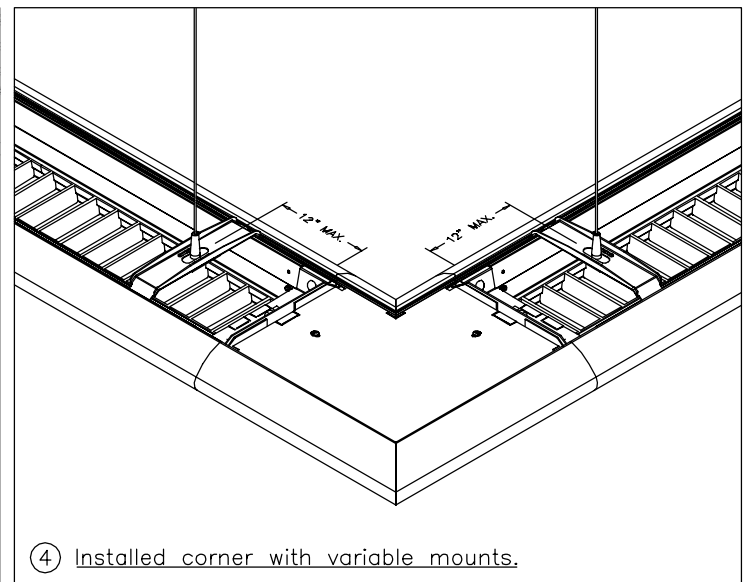
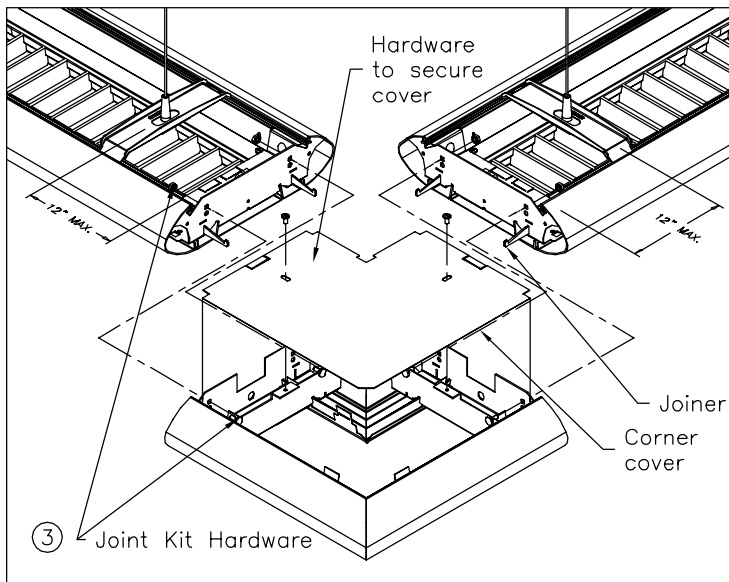
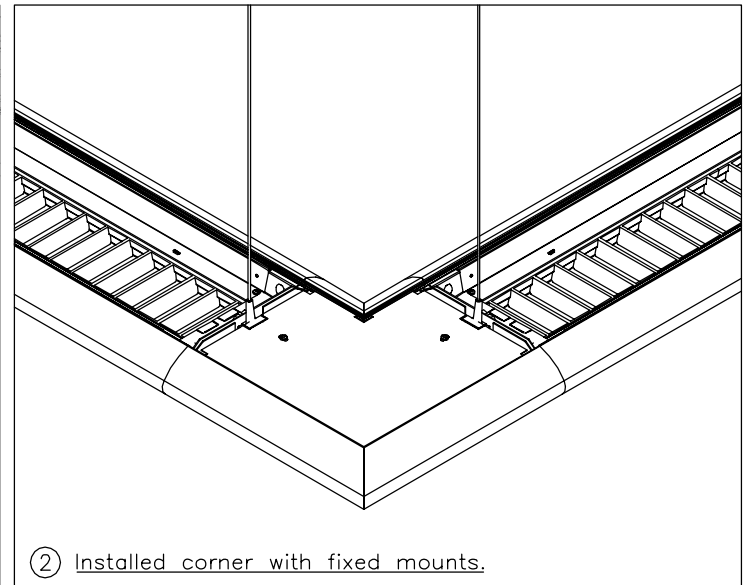
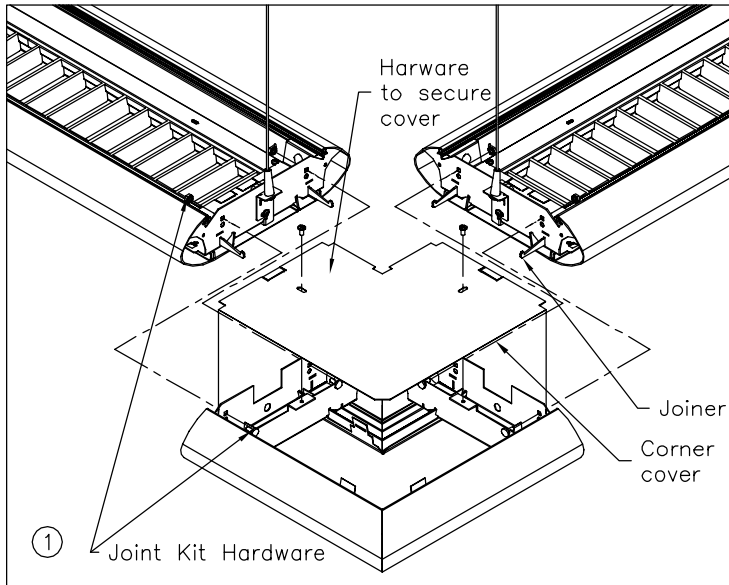
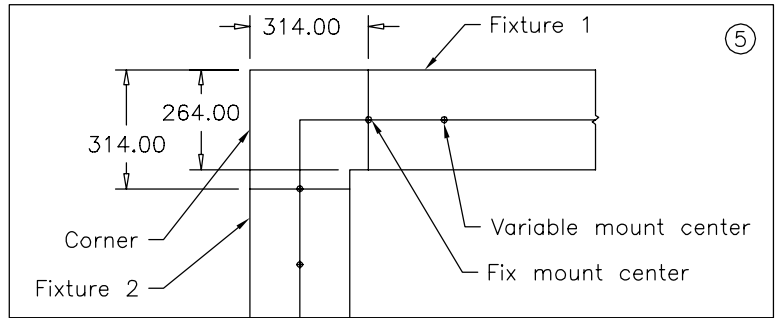

### Installation Instructions – Pendant Mount

- ① Read All Installation Instructions Before Installing Fixtures.
- ② Layout boxed fixtures on floor in desired mounting locations. Remove fixtures from boxes but keep the protective plastic on during installation.
- ③ General installation sequence:
  - (A) Install ceiling mounting kits (see below).
  - (B)&(C) Attach fixtures to mounting brackets at ends and joints (see below).

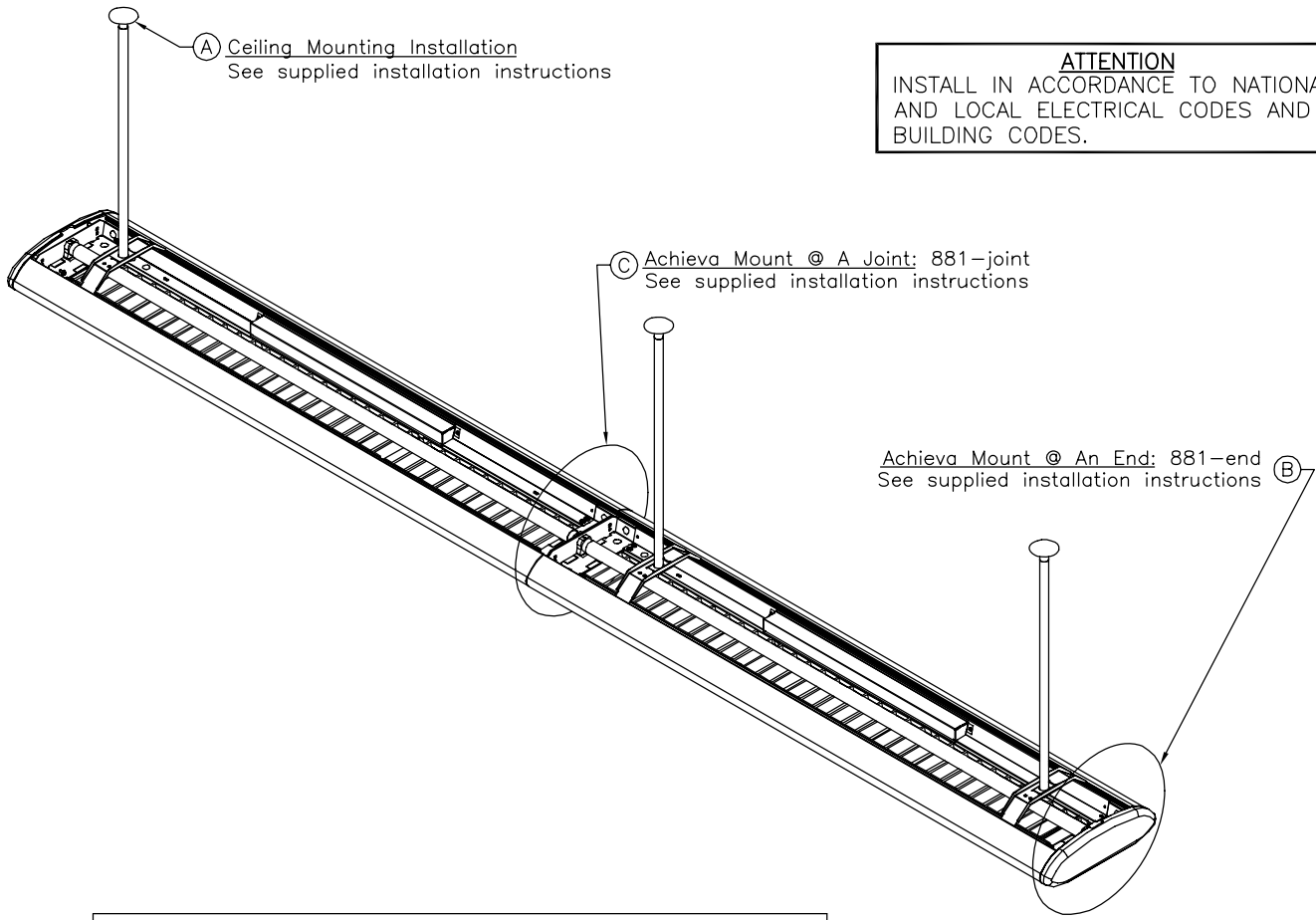

**ATTENTION**  
INSTALL IN ACCORDANCE TO NATIONAL  
AND LOCAL ELECTRICAL CODES AND  
BUILDING CODES.

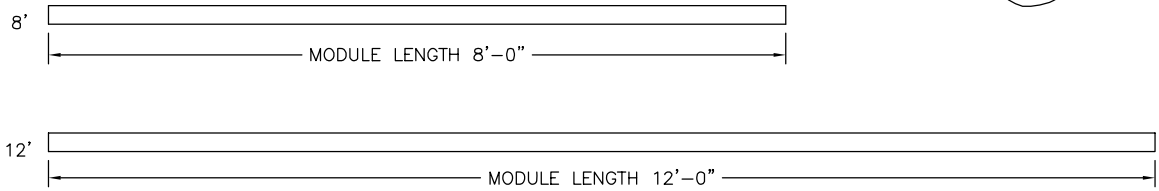

Overall Fixture Lengths

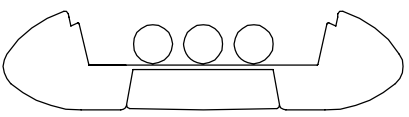

Cross Section

Ae101\_K4\_8002/1/1/50

## Installation Instructions

- ① Insert pendant pipe in pendant mount bracket.
- ② Slide variable pendant mount sleeve over power cord leads. Run power cord leads up into the pendant pipe at power feed location. Slide variable pendant mount sleeve up into the pendant pipe.
- ③ Install ceiling components.  
(See supplied "Mounting Installation" instructions.)
- ④ Install pendant pipe into ceiling component leaving pendant mount bracket suspended on pendant pipe.
- ⑤ Hang fixture by sliding pendant mount brackets into extrusion chase of fixture. Ensure mounting bracket is no more than 12 inches from end of fixture.
- ⑥ For a power feed location, break required 1/2 inch knock-out(s) in wire access cover and insert supplied bushing(s). Feed pendant mount sleeve approximately 3" into the access cover with bushing. Feed sleeve with power cord along reflector and up under pendant mount bracket and secure with tie wrap (supplied by others). Excess sleeve can be run up into the pendant pipe before securing tie wrap. Use strain relief under wire access cover to secure cable leads. Remove installed quick-wire connectors at power feed location and complete electrical connections using wirenuts (supplied by others).
- ⑦ Confirm fixtures are level; if not, make fine adjustments as required. Adjust height by lifting fixture to release pendant pipe welded plate from orientation tabs of pendant mount bracket. Rotate pendant pipe clockwise to raise fixture and counter-clockwise to lower fixture. Lower fixture on to pendant mount bracket ensuring pendant pipe welded plate is between orientation tabs.
- ⑧ Attach endcaps with supplied hardware.

**NOTE:**  
NO VARIABLE MOUNTS ON 4' FIXTURES

**ATTENTION**  
INSTALL IN ACCORDANCE TO NATIONAL AND LOCAL ELECTRICAL CODES AND BUILDING CODES.

Power Feed Connection

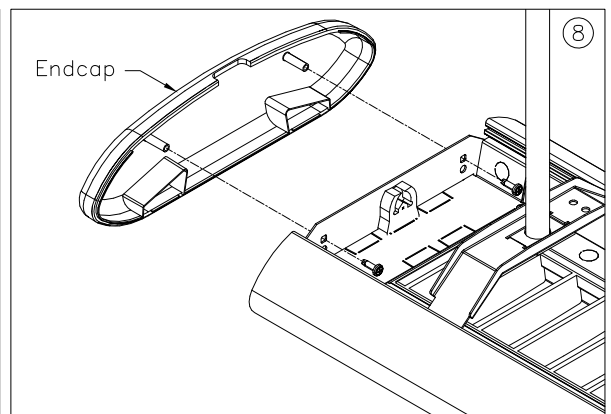
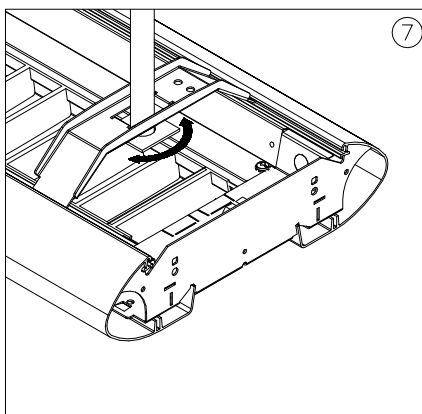
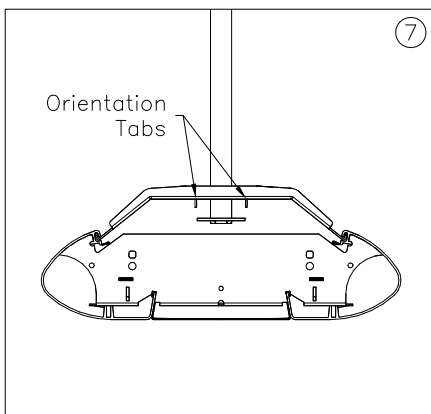
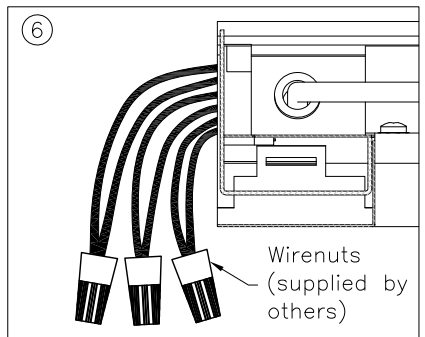
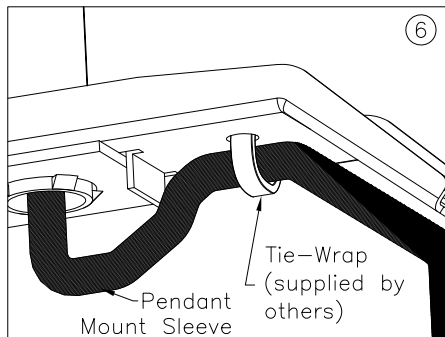
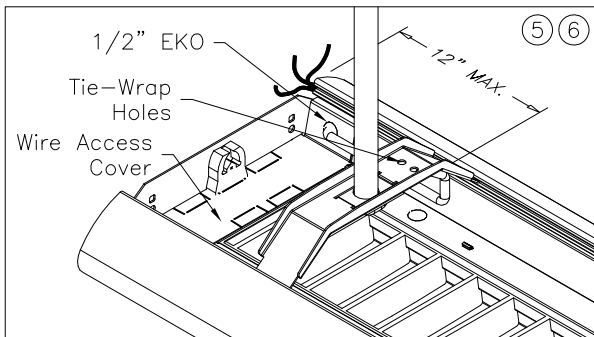
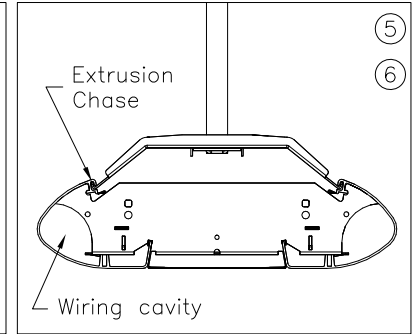
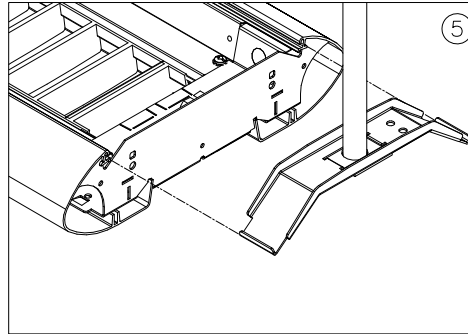
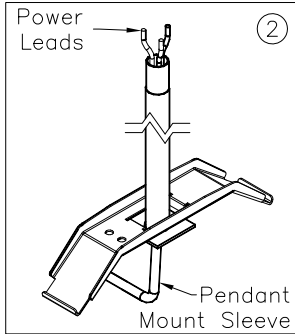
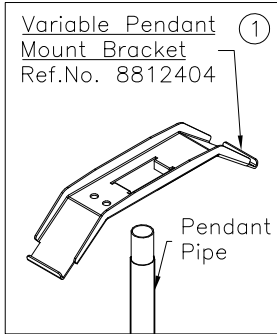

## Installation Instructions

**ATTENTION**  
INSTALL IN ACCORDANCE TO NATIONAL AND LOCAL ELECTRICAL CODES AND BUILDING CODES.

- ① Insert pendant pipe in pendant mount bracket.  
(See supplied "Achieva Mount @ End" instructions)
- ② Run power cord through pendant pipe at power feed locations.
- ③ Install ceiling components. (See supplied "Mounting Installation" instructions.)
- ④ Install pendant pipe into ceiling component leaving pendant mount bracket suspended on pendant pipe. (will be used in step 6)
- ⑤ Insert joiners into crossplate of first fixture and lock in place. Set next fixture on joiners ensuring fixture is held by hooks of joiner ends.
- ⑥ Hang opposite fixture end by sliding pendant mount brackets into extrusion chase of fixture. Ensure mounting bracket is no more than 12 inches from end of fixture.
- ⑦ For a power feed location, break required 1/2 inch knock-out(s) in wire access cover and insert supplied bushing(s). Feed power cord along reflector and through as shown. Route cable under pendant mount bracket using tie-wrap (supplied by others). Use strain relief under wire access cover to secure cable. Remove installed quick-wire connectors at power feed location and complete electrical connections using wirenuts (supplied by others). Ensure that all connections are properly matched, capped, and tucked into fixture wiring cavity.
- ⑧ For a non power location, push wires into supplied quick connectors. **DO NOT TWIST WIRES PRIOR TO CONNECTION. If power supply wires are on opposite sides of fixture, remove wire access cover (see 7), bring power wires to one side and complete connections as shown.** Ensure that all wiring connections are properly matched, capped, and tucked into fixture wiring cavity. Replace wire access cover and associated screws if necessary.
- ⑨ Secure fixtures together using hardware supplied in joint kit. Ensure star washers face crossplate.
- ⑩ Confirm fixtures are level; if not, make fine adjustments as required (See supplied "Achieva Mount @ End" instructions). Adjust height by lifting fixture to release pendant pipe welded plate from orientation tabs of pendant mount bracket. Rotate pendant pipe clockwise to raise fixture and counter-clockwise to lower fixture. Lower fixture on to pendant mount bracket ensuring pendant pipe welded plate is between orientation tabs.

